

TECHNICAL INFO

IM: 17Vcc (1 PAIR UTP)
 2M: GND (1 PAIR UTP)
 3M: DATA (1 PAIR UTP)
 VIDEO: 1 PAR UTP
 FOR DIFFERENT SPECIFICATIONS,
 CONTACT MANUFACTURER

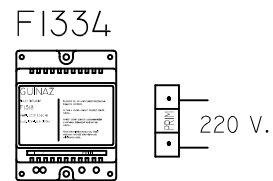

ALL THE IMAGES ARE GUINAZ S.L. PROPERTY.

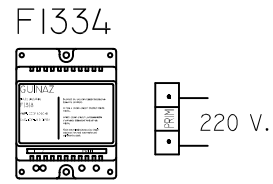
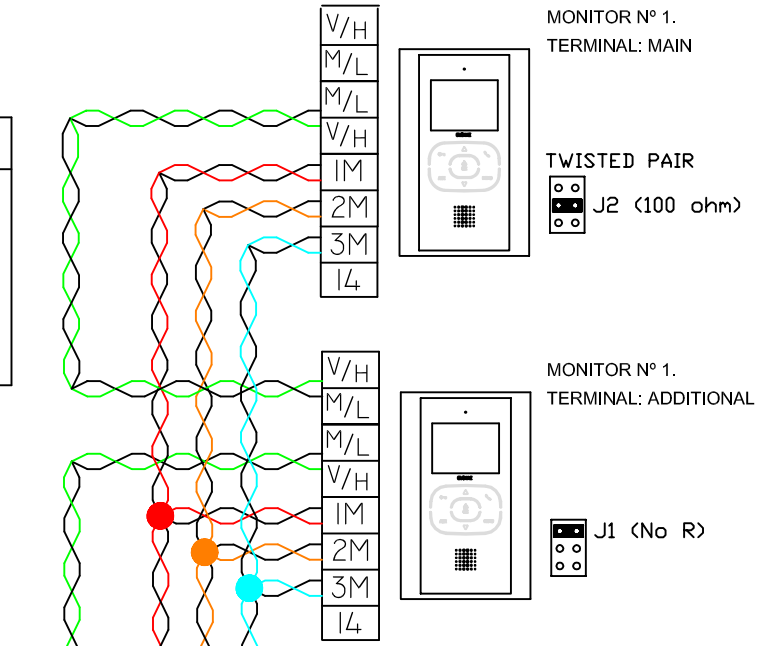
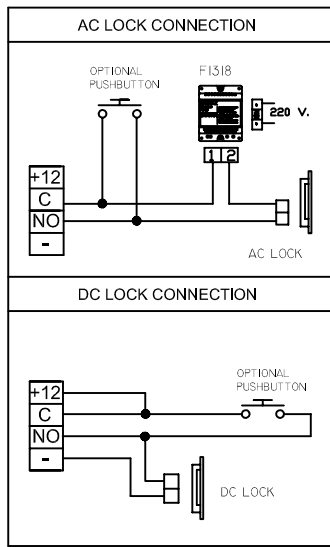